

# BERGAMO

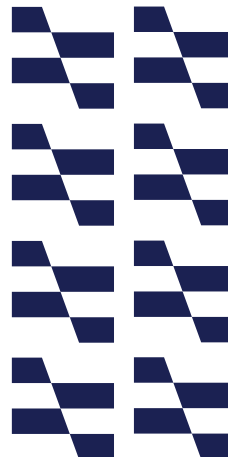

**7,914 Sq M**  
Prime Distribution/Warehousing  
Facility On A Site Of **5.89 Hectares**

Leasehold Opportunity

Via Monte Alben,  
**24060** Chiuduno, Bergamo, Italy

**AVAILABLE IMMEDIATELY**



Country Map

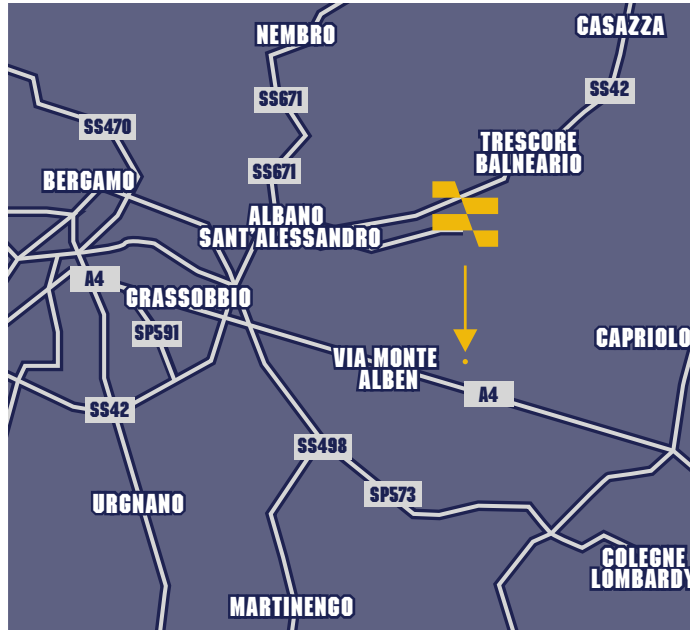

Micro Location Map

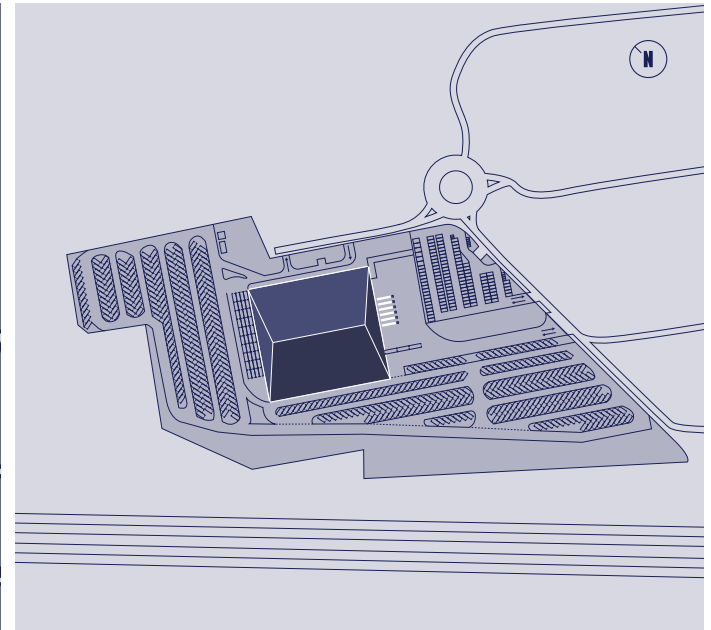

Site Plan

## LOCATION

Located in the Eastern part of Lombardy region, the most developed Logistics macro-area in Italy, Chiuduno warehouse is well positioned in front of the A4 motorway, a 4-minute drive to Grumello-Telgate Tollgate (2 Km). Prime location in order to serve Bergamo city centre (25 minutes' drive, 17.8 Km) and Bergamo Orio al Serio Airport (20 minutes' drive, 17.6 Km).



15 M  
Eaves Height



22.1 KM To  
Bergamo



Class A Distribution/  
Warehousing Facility



5.89 Hectares  
Site Area



Secure  
Yard



8 Dock Level  
Loading Doors



Flexible Lease Terms  
(Available On Request)

## Further Information



**Alessandro Gazzari**  
+39 026 379 9325  
alessandro.gazzari@cushwake.com

**Filippo Maria Di Caprio**  
+39 348 026 4511  
filippo.dicaprio@cushwake.com

© Cushman & Wakefield. The material in this presentation has been prepared solely for information purposes, and is strictly confidential. Any disclosure, use, copying or circulation of this presentation (or the information contained within it) is strictly prohibited, unless you have obtained Cushman & Wakefield's prior written consent. The views expressed in this presentation are the views of the author and do not necessarily reflect the views of Cushman & Wakefield. Neither this presentation nor any part of it shall form the basis of, or be relied upon in connection with any offer, or act as an inducement to enter into any contract or commitment whatsoever. No representation or warranty is given, express or implied, as to the accuracy of the information contained within this presentation, and Cushman & Wakefield is under no obligation to subsequently correct it in the event of errors. December 2022. Designed and produced by CORMACK - cormackadvertising.com